

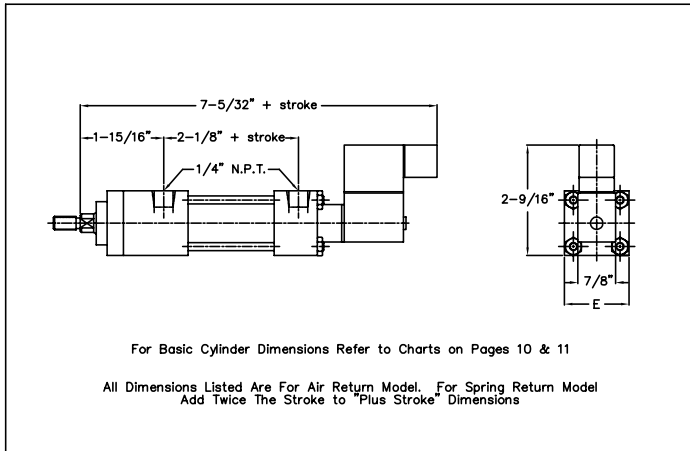

## JHDA AIR MOTOR AIR CYLINDER WITH MOUNTED VALVE

### JHDA 01 AIR MOTOR: 1" DIA. BORE



The JHDA 01 series air motor combines the rugged 1" dia. bore JHD 01 heavy duty air cylinder (pp.12-13) with an electric solenoid valve to create a cylinder and valve designed as a unit. One electrical connection and a single air supply line to the valve-in-head end of the cylinder simplifies installation. (For an air return model, a constant pressure air line must be connected to the rod end port of the cylinder.)

The standard valve used is a miniature 3-way solenoid operated valve, 110 volt, 60 cycle, with power consumption of 6 watts, continuous duty rated, Class A, molded coil. The electric connection is via spade terminal coil with ground per DIN 43650. Other coil voltage, connectors and enclosures are available.

The JHD01 cylinder mountings available are: 01, 04, 06, 09, 10, 11, 12, 13 (see pp. 12-13).

Consult factory for available options such as Miracalube®, spring return, and low pressure air operation, or for specials

### JHDA AIR MOTOR: 1 1/2" to 8" DIA. BORE

The JHDA series air motor in sizes from 1 1/2" to 8" dia bore features the JHD heavy duty air cylinder and Lehigh's 4-way Slide Valve to create a linear motion, quick-response power package. This combination unit eases installation and reduces power and maintenance costs.

A variety of cylinder mounting designs is available, as well as electric solenoid options. See pp.14-28 for JHD cylinder information and p.40 for description of the slide valve features and function.

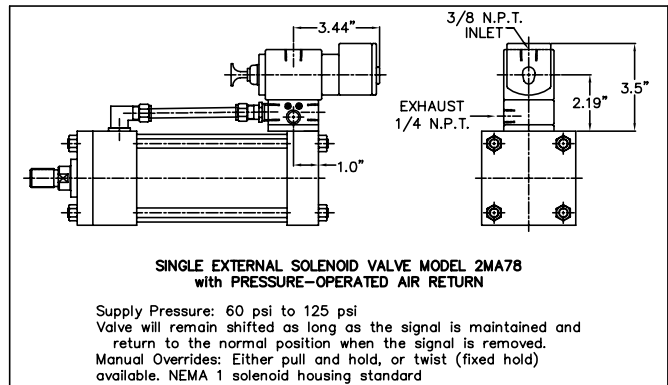
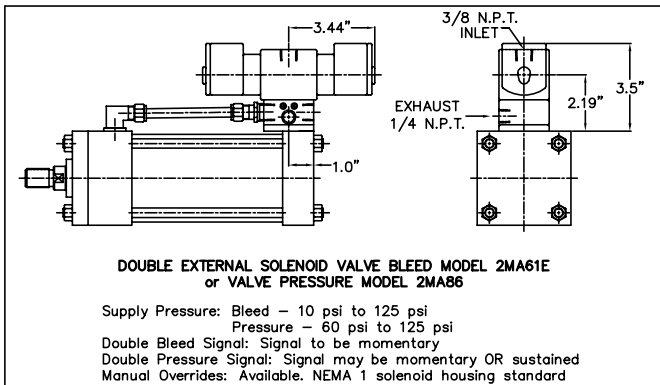
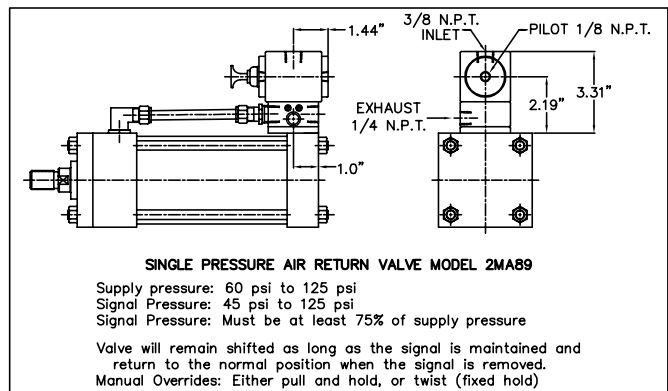
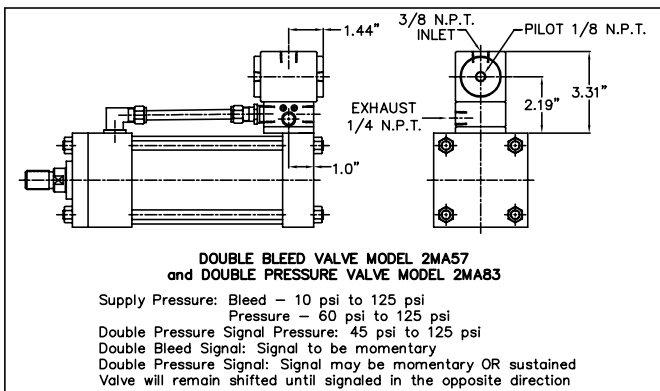

## JHDA AIR MOTOR (Cont.)

### SPECIAL ELECTRICAL COIL

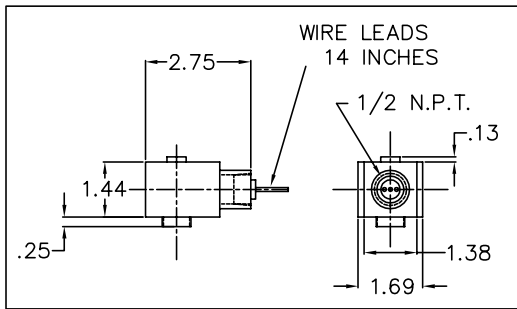

The special electrical coil shown at the left is available at extra charge. This water-tight and explosion proof enclosure is for indoor or outdoor use in NEMA groups 4, 6, 7C, 7D, 9E, 9F 9G and 12.

Piping arrangements are slightly different from the standard NEMA 1 housing.

Specify "NEMA 4, 7, and 9."

### AUTOMATIC AIR MOTOR

#### AUTOMATIC AIR MOTOR: 2" to 8" DIA. BORE

The JHDA series automatic air motor in sizes from 2" to 8" dia bore use built-in poppets to provide the signal for automatic operation of the JHD heavy duty air cylinder. External limit valves, micro-switches and push rods are eliminated. Mounted internally in the head, the poppets bleed off the signal side of the control valve when the piston depresses the poppet stem at the end of the stroke. Safe, reliable, and positive, the system provides a simple and low cost method of automatic operation.

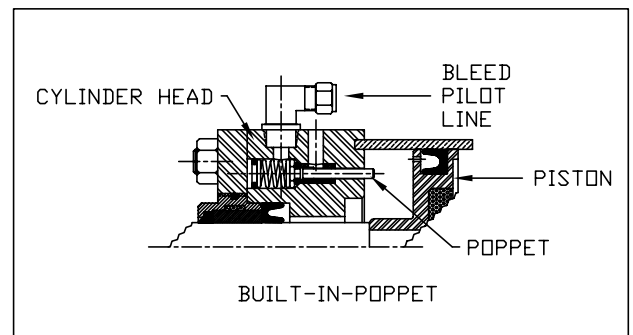

#### AUTOMATIC RETURN

Automatic return air motors have the built-in poppet in one head to automatically reverse the stroke from the normally retracted or normally extended position. The start cycle may be controlled by bleed or electrical signals

#### AUTOMATIC RECIPROCATING

Automatic reciprocating air motors have the built-in poppets in both heads and will maintain a reciprocating action as long as the air supplied is provided. A start-stop selector valve may be installed in either pilot line to assure that the stroke will terminate at one extreme or the other.

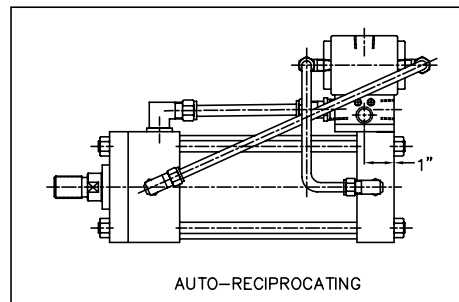
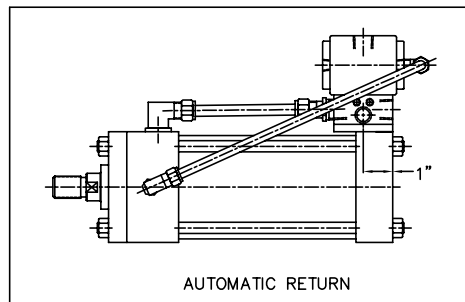

All the mounting styles of the JHD air cylinder are available for the automatic air motor.

The 2" dia. bore automatic air motor is limited to a maximum 5/8" diameter rod size. The 2-1/2" dia. bore automatic air motor is limited to a maximum 1" diameter rod size. There is no rod diameter limitation on larger bore sizes.

### ORDERING INFORMATION FOR JHDA AIR MOTORS

Use the ordering part number system shown on p.33 for the standard JHD air cylinder. The air motor is designated in the last two places with "01". Note the requirements and restrictions for the particular type of air motor described in this section, and add the applicable description; e.g., valve model, voltage, optional electric enclosure, automatic return air motor, etc.



# JHDA AIR MOTOR VALVES

## SERIES 2MA 4-WAY SLIDE VALVE

This exclusive pneumatic slide valve was designed specifically for Lehigh's line of Air Motors, yet it can be used in other air-powered device applications. It features **Fast Acting** operation . . . Up to 1,500 cycles per minute. It is **Reliable** . . . Operating even with improperly filtered air. It offers **Long Life** . . . The metal-to-metal seat is self-cleaning and operates for millions of cycles without significant wear. It is **Compact** . . . The short piston permits short valve length

### HOW IT OPERATES

The air-driven piston moves the slide. In each of its two positions, the slide opens one exhaust and one pressure port. The rate of flow of exhaust air is controlled by adjustable speed controls mounted in each of the two exhaust orifices. Both these orifices lead to a single exhaust port. The oversized actuating piston assures positive breakaway action, regardless of dirt in the operating areas or of low operating pressures. The slide effectively wipes the seat clean on each cycle, assuring a satisfactory seal even when used with improperly filtered air.

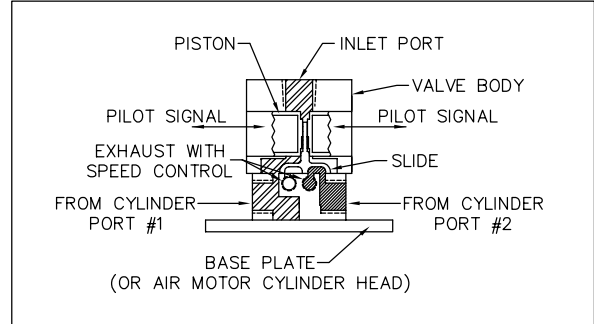

### CONSTRUCTION

**Piston:** Corrosion resistant anodized aluminum on all valves except 316 stainless steel on valve model 2MA57 AND 2MA61E double bleed valves. **Slide:** Lapped manganese bronze. **Valve Base:** Lapped nickel-plated ductile iron. **Valve Body:** Anodized heat treated aluminum.

### MOMENTARY BLEED PILOTS

The balanced piston is actuated by momentary unbalancing caused by the pilot air exhausting from the opposite signal port. The exhausting of pilot air is actuated by double solenoids integrally mounted on the valve (**Model 2MA61E**) or actuated by pilot air from valves in the customer's control circuit (**Model 2MA57**).

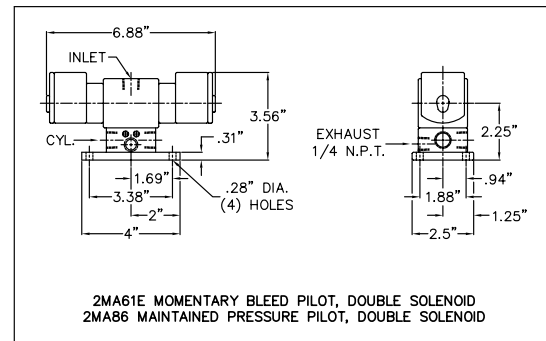

### MAINTAINED PRESSURE PILOTS

Positive maintained pilot pressure is used move the piston/slide mechanism, holding it in the desired actuated position. The pilot air is actuated by double solenoids integrally mounted on the valve (**Model 2MA86**) or actuated by pilot air from valves in the customer's control circuit (**Model 2MA83**).

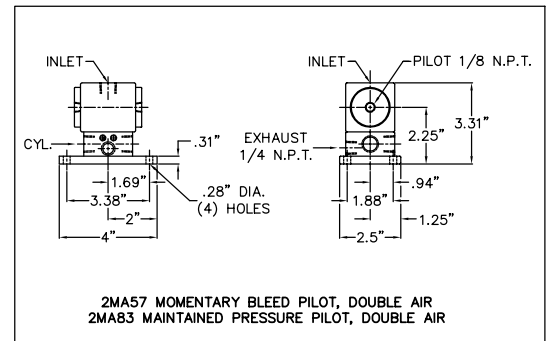

### AIR RETURN

The piston/slide mechanism can be supplied with one end having a smaller diameter in order to create a differential force when both sides are subjected to the same air pressure. The larger end will overpower the smaller end, causing movement toward the smaller end. When air in the larger diameter is exhausted, line pressure acting on the smaller end automatically activates the return. Control is by a single solenoid integrally mounted on the valve (**Model 2MA78**) or by single pilot air actuation from a valve in the customer's control circuit (**Model 2MA89**).

